



IUT-5204 4Port RS-485 HUB Instruction manual

I . Overview

UT-5204 is a RS-485 bus-division hub designed for RS-485 system used in complicated electromagnetic environments. It supports data communication rate up to 115.2KBPS. Photoelectric isolation technique is introduced to the RS-485 interface to prevent converter and device from lightning and surge voltage for ensuring the safe and reliable data communication. The built-in photoelectric isolator (an isolation voltage as high as 2.5KVrms) and 600W surge suppressor can effectively suppress lightning and ESD and the grounding interference with each RS-485 line. It uses external switching power supply for safety and reliability and is ideal for outdoor engineering applications. The built-in discrimination circuit can automatically sense the direction of data flow and switch the enable control circuit to ensure the automatic switch of transmit and receive in RS-485 mode.

RS-485 is widely used in thruway toll system, road supervision system and electric power acquisition system as a high-performance and economical data interface converter. Short-circuit and open-circuit protection are provided for each port. Users can improve the RS-485 bus structure and divide bus segments conveniently for improved communication reliability. If lightning or faults occur then the failed segment will be isolated and make sure other segments can operate normally.

This feature significantly improves the reliability of existing RS-485 network and reduces maintenance interval. Reasonable use of UT-5204 RS-485HUB can help to design a unique, highly reliable RS-485 system.

、.I.Features:

- 1、 Interface: Compatible with RS-232 and RS-485 standards of EIA/TIA

2. Electric connection: 10-bit wiring terminal for both RS-232 and RS-485 interface
3. Transmission media: twisted-pair cable or shielded cable
4. Operation mode: Asynchronous half-duplex
5. Power supply: 9-30VDC/350mA
6. Signal indication: 7 signal indicators - Power (PWR), Transmission (TD), Receive(RD), Error (E1-E4)
7. Isolation voltage: continuous 2.5KVrms /500VDC isolation DC/DC module
8. Data rate: 115.2K-300BPS
9. Protection class: +/-15KV ESD protection for RS-232 interface; 600W lightning strike and surge protection for each RS-485 line.
10. Communication distance: 0-5 KM(115200bps-300bps)
11. Dimension: 120mm×72mm×22mm
12. Working environment: -25℃to 70℃, relative humidity of 5% to 95%

III、 Panel and signal indicator

There are 7 indicators on the front panel of UT-5204 and two 10-bit wiring terminals on the left and right end. TXD,RXD, GND on left side are signal input terminal of RS-232, 485+ and 485- are signal input terminal of RS-485, and GND is ground. T/R1+,T/R1-,T/R2+,T/R2-,T/R3+,T/R3-,T/R4+,T/R4- ,GND, GND on the right side are signal output terminals of RS-485. Please note that GND of 485 output and GND of input can't be connected together.

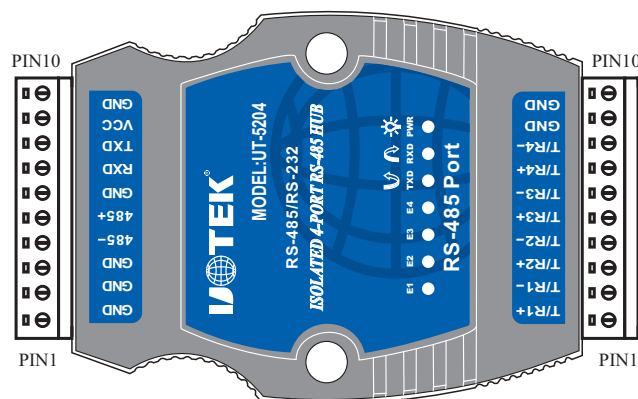

Meanings of indicator lights on the front panel of UT-5204

- PWR power indication, normally red
- TXD Data transmitting indication, normally flashing green, indicating that the data is transmitted from INPUT port to OUTPUT port 1- port 4
- RXD Data receiving indication, normally flashing yellow, indicating that the data is transmitted from OUTPUT port 1- port 4 to INPUT port
- E1-E4 error alarm indication for port1-port4; If it's permanently illuminated then short-circuit or reverse connection exists on the RS-485 interface devices connected to port1-port4, and E1 light corresponds to port 1, and E4 light corresponds to port 4. Users can determine the fault port and the connected fault device according to the state of these fault alarm indicator lights.

、 IVElectric interface and its definition :

RS-232C interface definition

10-bit wiring terminal	Definition	Signal description
1	GND	Ground
2	GND	Ground
3	GND	Ground
4	485-	RS-485 Negative signal input
5	485+	RS-485 Positive signal input
6	GND	Ground
7	RXD	RS-232 Signal receive
8	TXD	RS-232 Signal transmit
9	VCC	Power input DC+9-40V
10	GND	Power Ground

RS-485 interface definition

10-bit wiring terminal	Definition	Signal description
1	T/R1+	RS-485 signal output +
2	T/R1-	RS-485 signal output -
3	T/R2+	RS-485 signal output +
4	T/R2-	RS-485 signal output -
5	T/R3+	RS-485 signal output +
6	T/R3-	RS-485 signal output -
7	T/R4+	RS-485 signal output +
8	T/R4-	RS-485 signal output -
9	GND	Isolation ground
10	GND	Isolation ground

V Typical UT-5204 4-port RS-485HUB applications

1、 RS-232C serial port of master device to 4 highly reliable RS-485 interface

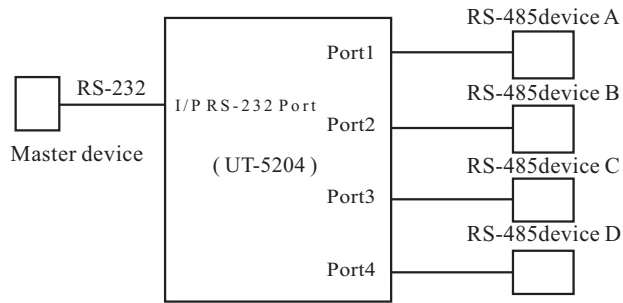

2、 Extend the existing RS-485 bus to 4 highly reliable RS-485 interfaces, and maximum 128 RS-485 hubs can be connected to the RS-485 bus in parallel

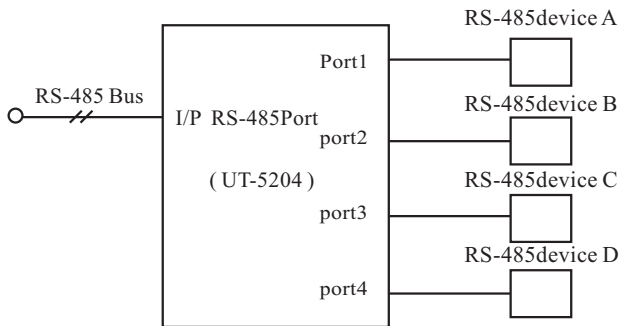

3、 Serial port of master device (RS-232C) to multiple highly reliable RS-485 interface

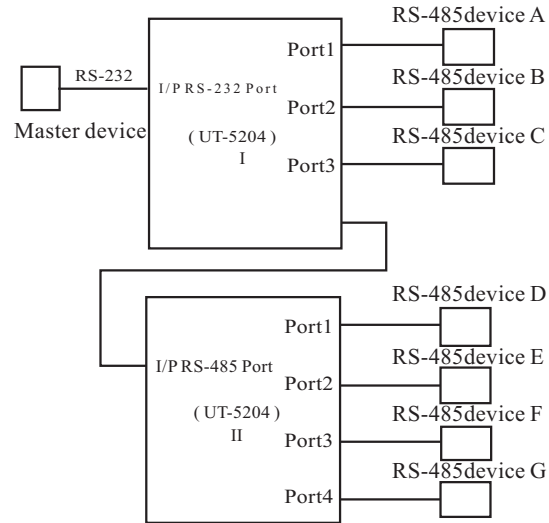

4、 Extension of existing RS-485 bus to multiple highly reliable RS-485 interfaces, and maximum 128 RS-485 hubs can be connected to the RS-485 bus in parallel

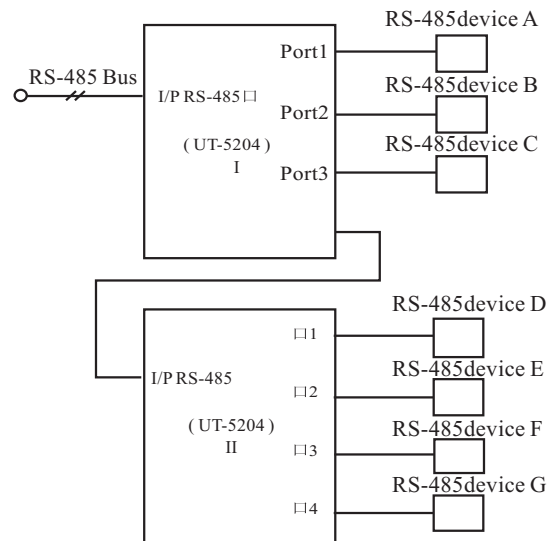

VI Error alarm and protection of RS-485

Error alarm and protection of RS-485 interface is effective for connecting multiple RS-485 devices and enhancing its reliability. There are 4 subordinate ports on UT-5204 which can be used to determine quickly the faulty ports and the connected faulty devices according to error indicators. Each port is equipped with short-circuit protection and can operate in turn-off mode. Any one fault RS-485 port only can influence the bus system in which it exists and other system can still operate normally.

VII Power supply and lightning protection

DC power supply of +9 V - +40V / 350mA min is used for powering the UT-5204. Lightning protection of 600W is provided for each RS-485 port of the UT-5204, and it can effectively suppress lightning and ESD.

Port 4 of UT-2204 is the protective earth of surge protection and it's must be grounded reliably to avoid being hanged in the air for ensuring the communication safety.