

UT-2209 RS-485 Photoelectric Isolation Data Repeater User Manual

I. Summary

Compatible with the Recommended Standards of RS-485, UT-2209 photoelectric isolation data repeater can extend the communication distance of RS-485 signal switchboard network and increase the number of RS-485 network equipments. The built-in photoelectric isolator and DC/DC isolation module can provide an isolation voltage of as high as 250Vrms. Also, there is a rapid transient voltage suppression protector for the protection of RS-485 interface with the advanced TVS (TRANSIENT VOLTAGE SUPPRESSOR) technology adopted. Under normal conditions, the TVS tube is in the state of high resistance. However, when both ends of the TVS tube are hit by a transient high energy, the impedance at both ends can be depressed by the TVS at a very high speed, and after absorbing a high current, the voltage between the two ends is suppressed and kept at a pre-set value, therefore no damage is caused to the electrical components behind by the transient high voltage impact. The protector can effectively restrain lightning or ESD (electrostatic discharge) with a protection voltage of 600W on each line for lightning surge and surge voltage or transient over voltage possibly caused up by various reasons, and at the same time, a high-speed transmission of RS-485 interface is ensured by the tiny capacitance between the poles. The RS-485 input terminal is connected by two bits connector terminal. The RS-485 output terminal is connected by the two bits connector terminal too. The unique I/O circuit of the internal zero delay auto transceiver contained in the converter controls the data stream direction automatically without any handshaking signal (for example RTS, DTR etc). The converter is plug-and-play without any jumper settings needed for mode shift mode shift half duplex RS-485.

A reliable and stable point-to-point and point-to-multipoint communication can be ensured by UT-2209 photoelectric isolation interface converter. For point-to-multipoint communication, as many as 128 interface facilities of RS-485 standard can be connected to each converter, and a high data transmission rate of 300-115.2Kbps can be achieved. Power indicator light and data traffic indicator light are also available with the converter for malfunction indication.

II. Performance parameters

1. Interface characteristic: compatible with the standards of RS-485 issued by EIA/TIA.
2. Electric interface: The RS-485 input terminal is connected by two bits connector terminal.
The RS-485 output terminal is connected by the two bits connector terminal too.
3. Protection Grade: Impose a protection of 600W on each line of RS-485 interfaces for lightning surge, ± 15KV ESD protection.
4. Isolation degree: isolation voltage 2500Vrms 500DC non-stop.
5. Operation mode: asynchronous half duplex.
6. Signal indication: 3 pilot lamps for Power (PWR), Send (TXD) and Receive (RXD).
7. Transmission media: twisted pair cable or shielded cable.
8. Transmission rate: 300-115.2Kbps.
9. Dimensions: 89mm × 73mm × 22mm.
10. Working Circumstance: -40°C to 85°C, relative humidity 5%-95%.
11. Transmission distance: 0-1,200meters (115,200bps-9,600bps).

III. Connector and signal

RS-485 input terminal signal bay-line distribution

Terminals(Pin)	Signal Definitions	Signal Description
1	VCC	DC9-24V input
2	GND	Power ground
3	T/R+	RS-485+ input
4	T/R-	RS-485- input
5	T/R+	RS-485+ Isolated output
6	T/R-	RS-485- Isolated output

IV. Hardware installment and application

Read the user manual carefully before installing the UT-2209 photoelectric isolation data repeater. Then insert the power supply converter to power socket. The product adopts the Terminals general used connector for input and output interface without jumper setting for RS-485 automatic communication mode. Either twisted pair cable or shielded cable is applicable for easy installation or un-installation.

UT-2209 interface converter supports the following 2 communication modes:

1. Point-to-point 2-line half duplex
2. Point-to-multipoint 2-line half duplex

In order to prevent the signal reflection or interference when converter is used in half-duplex mode, a proper matching resistance should be connected at the terminal of the line (120Ω 1/4W).

V. Communication connection chart

RS-485 2-line relay conversion

1. RS-485 point-to-point 2-line half duplex relay communication

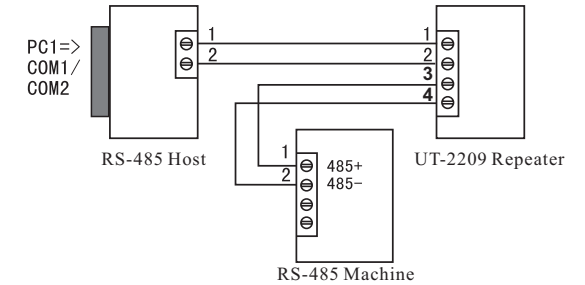

2. RS-485 point-to-multipoint 2-line half duplex relay communication

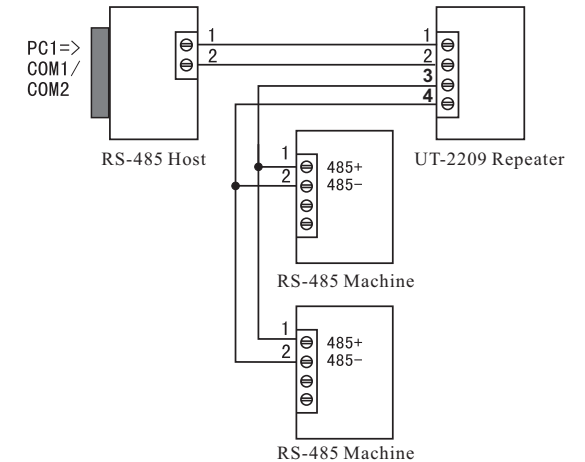

VI. Problems and resolutions

1. Data communication failure
 - A. Make sure RS-485 input interface connection is correct.
 - B. Make sure RS-485 output interface connection is correct.
 - C. Make sure power supply is OK.
 - D. Make sure the wire terminal connection is OK.
 - E. Make sure the pilot lamp flashes when receiving.
 - F. Make sure the pilot lamp flashes when sending.
2. Data missing or incorrect
 - A. Check to see whether if the data rate and format at both ends of the communication equipment are consistent.