

UT-1208H 8-PORT RS-485 HUB USER MANUAL

I. Summary

With a double-core and non-stop inside design, UT-1208H is a RS-485 bus splitting hub specially designed to meet the requirements of RS-485 under sophisticated electromagnetic field environment. A transmission rate as high as 115.2 KBPS is supported by this product. What's more, photoelectrical isolation technology is adopted for RS-485 interface to avoid induction of lightning or surge into the converter and equipments to make sure the safety and reliability of signal transmission. The built-in photoelectrical isolator and the 1,500W surge protection circuit can provide a high isolation voltage of 2,500V for an efficient restriction of lightning and ESD, and at the same time, lightning strike and grounding interference can be reduced to the least extent. This product is suitable for outdoor engineering with adoption of outside switch power supply.

Under RS-485 mode, the determination circuit adopted can determine the direction of the data stream and switch the control circuit on a automatic basis for a very easy solution of the long-existed transmission delay of RS-485. The transmission distance is as far as 1,200 meters with a very stable performance. This product is widely used in expressway toll system, road monitoring system and electricity monitoring system with nice performance and competitive price.

RS-485 star topology bus connection is provided by UT-1208H RS-485 HUB. Short circuit and open circuit is provided for all the terminals. Photo electrical isolation of 2,500V is provided. Re-construction of RS-485 bus structure and network range splitting can be easily realized to improve communication reliability. In the case of lightning strike or equipment failure, the affected range shall be isolated to make sure the normal function of other ranges. This feature can increase greatly the reliability of existing RS-485 with achievement of shorter time for network maintenance. Proper application of UT-1208H RS-485 HUB can help you with a nice design of RS-48 system of high stability.

II. Parameters

- Interface features: compatible with RS-232C and RS-485 standards of EIA/TIA.
- Electric interface: RS-232C interface for the 1st -3rd pins of the 5-PIN terminals, and RS-485 interface for the 4th 5th pins of the 5-PIN terminals.
- Transmission media: twisted-pair cable or shielded cable.
- Working mode: asynchronous half-duplex.
- Signal indication: 12 signal indicator including power (PWR), send (TXD), receive (RXD) and failure (E1-E8).
- Isolation degree: a isolation voltage of 2,500V RMS 500VDC non-stop and DC/DC isolation module.
- Transmission rate: 300BPS-115.2K.
- Protection grade: RS-232 interface 15KV ESD protection, RS-485 interface 1,500W lightning strike surge protection for each line.
- Transmission distance: 0-5km (115,200-300BPS)
- Measurements: 210mmX130mmX33mm
- Working environment: -40°C to 80°C, relative humidity 5% to 95%.

II. Panel and signal indicators

There are 11 indicator lights on the front panel of UT-1208H, and on the back panel there are 1 5-pin terminal for RS-485 or RS-232 input and 8 ports 3-pin terminals for photo electrical isolation input ports.



Figure 1. Front Panel of UT-1208H

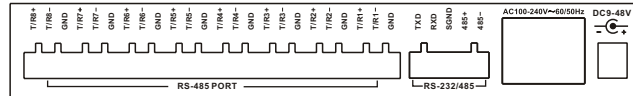

Figure 1. Back Panel of UT-1208H

Interpretation of frontpanel indicators:

- PWR--Power, green for power on.
- TXD--Data sending indication, green for normal transmission from INPUT port to OUTPUT ports 1-8.
- RXD--Data receiving indication, yellow for normal transmission from OUTPUT ports 1-8 to INPUT port.
- E1-E8--Failure alarm indicators for ports 1-8, the lights stay ON to indicate short circuit or wrong signal connection of ports 1-8. E1 is for port 1, E2 for port 2, and so on. Problems can be determined by the user according to different light indicators.

IV. Electric interfaces and definitions:

RS-232C/RS-485 definition

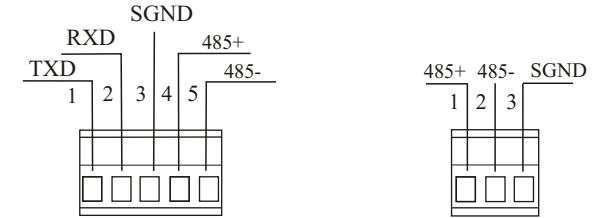

Fig 3. RS-232C/RS-485 input interface Fig 4. RS-485 output interface

1. RS-232C/RS-485 input interface definition

5-PIN Terminal Interface	Definition	Signal Direction
1	TXD	OUT
2	RXD	IN
3	SGND	
4	485+	
5	485-	

2. RS-485 output interface definition

5-PIN Terminal Interface	RS-485
1	485+
2	485-
3	GND

V. Applications of UT-1208H 8-Port RS-485 HUB

1. Application in connection from RS-232C serial port of main control machine to 8 RS-485 interfaces.

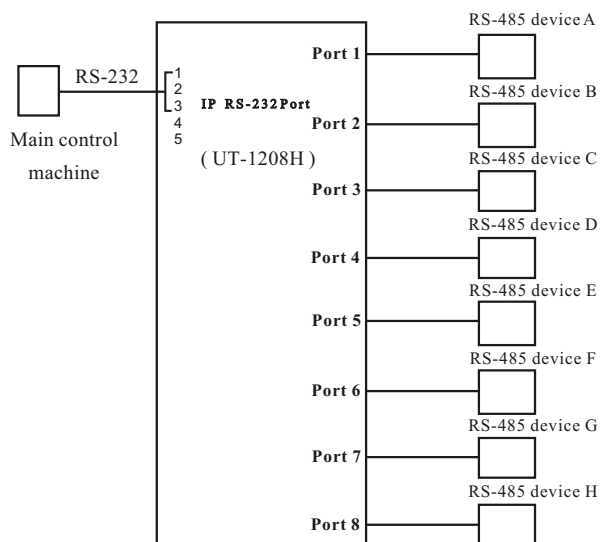

2. Application in expansion from existing RS-485 BUS to 8 RS-485 interface. A maximum of 128 RS-485 hubs can be connected simultaneously to RS-485 BUS.

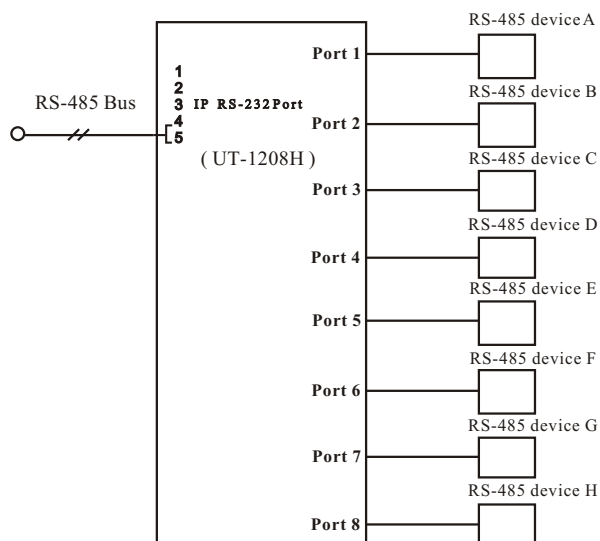

3. Applications in connection from RS-232C serial port of main control machine to multiple RS-485 interfaces, or in expansion from existing RS-485 BUS to multiple RS-485 interfaces, and a maximum of 128 RS-485 hubs can be connected simultaneously to RS-485 BUS.

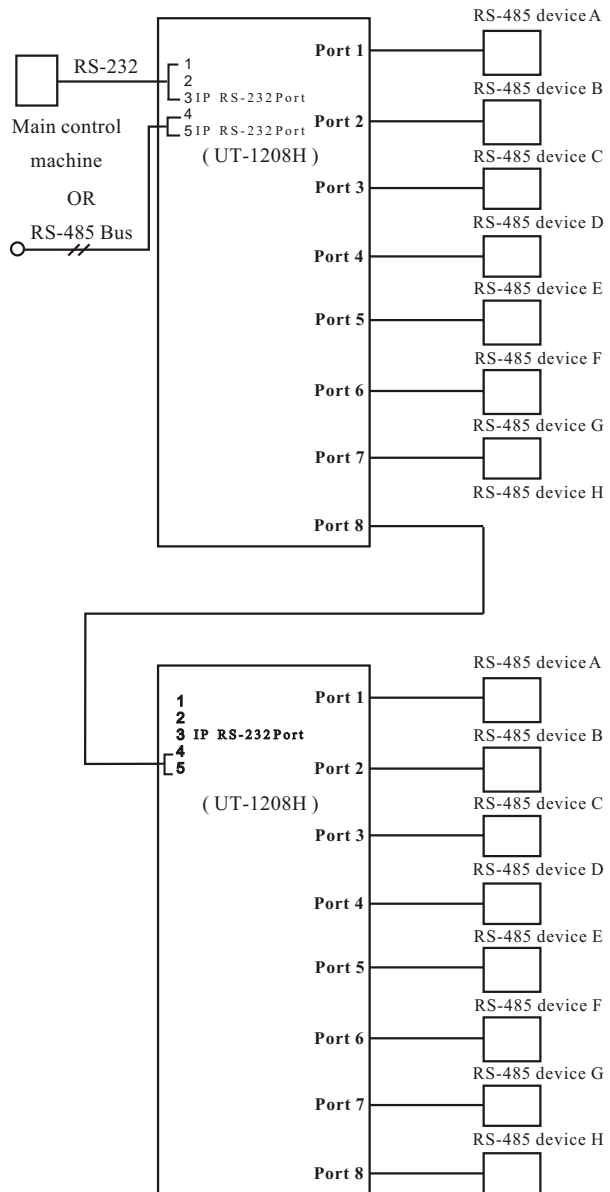

VI. Alarm and Protection of RS-485 Port Failures

Efficient solutions of RS-485 ports failures shall greatly increase the liability of RS-485 device connections. The short circuit protection function of all the 4 ports for subordinate machine shall work under turn-off mode. Any failure of any specific RS-485 port shall only influence the RS-485 BUS system connected to that port, all systems connected to other ports will not be effected. Failed ports and other devices connected can be determined easily for solution by users based on the alarm indicators.

VII. Protection of Power and Lighting Strike

Outside power supply of DC9-48V/AC100-240V~60/50Hz is adopted. Never use any other un-regulated power supply to avoid damage caused to your products.

1,500W lighting strike protection is available for all the RS-485 interfaces of UT-1208H for efficient restriction of lighting strike and ESD. Grounding has to be ensured for a safe and stable communications.