



RS-232/RS-485 UT-2216 Interface Converter User Manual

I. Summary

Compatible with the Recommended Standards of RS-232C, and RS-485, UT-2216 interface converter can convert the single-ended RS-232 signal into balance differenced RS-485 signal. Also, there is a rapid transient voltage suppression protector for protection of RS-485 interface with advanced TVS(TRANSIENT VOLTAGE SUPPRESSOR) technology adopted. Under normal conditions, the TVS tube is in the state of high resistance. However, when both ends of the TVS tube are hit by a transient high energy, the impedance at both ends can be depressed by the TVS at a very high speed, and after absorbing a high current, the voltage between the two ends is suppressed and kept at a pre-set value, therefore no damage is caused to the electrical components behind by the transient high voltage impact. The protector can effectively restrain lightning or ESD (electro static discharge) with a protection voltage of 600W on each line for lightning surge and surge voltage or transient over voltage possibly caused up by various reasons, and at the same time, a high-speed transmission of RS-485 interface is ensured by the tiny capacitance between the poles. Through a DB9 female connector RS-232 interface is connected to other interfaces compatible with RS-232C standard, and for RS-485 interfaces a DB9 male and RJ-45 connector is to be used for connection. The unique I/O circuit of the internal zero delay auto transceiver contained in the converter controls the data stream direction automatically without any handshaking signal (for example RTS, DTR etc). The converter is plug-and-play without any jumper settings needed for mode shift between half duplex (RS-485).

The converter is applicable for all the existing communication software and interface hardware without any software modifications for the previous working mechanism based on RS-232.

A reliable and stable point-to-point and point-to-multipoint communication can be ensured by UT-2216 photoelectric isolation interface converter. For point-to-multipoint communication, as many as 32 interface facilities of RS-485 standard can be connected to each converter, and a high data transmission rate of 300-115.2KBPS can be achieved. Power indicator light and data traffic indicator light are also available with the converter for malfunction indication. Two conversion communication modes including RS-232 to RS-485 are supported.

II. Performance parameters

1. Interface characteristic: compatible with the standards of RS-232C and RS485 issued by EIA/TIA.
2. Electric interface: DB9 female connector for RS-232 interface input end, DB9 male and RJ-45 connector for RS-485 interface output end.
3. Protection grade: +/-15KV ESD protection for RS-232 interface, and 600W surge protection each line for RS-485 interfaces.
4. Operation mode: asynchronous half duplex
5. Signal indication: 3 pilot lamps for Power (PWR), Send (TXD) and Receive (RXD).
6. Transmission media: twisted pair cable or shielded cable.
7. Transmission rate: 115.2KBPS to 300M, 38.4K BPS to 600M and 9,600 BPS to 1.2KM.
8. Dimensions: 97mm×65mm×22mm
9. Working circumstance: -20°C to 75°C, relative humidity 5%-95%.
10. Transmission distance: 0-1,200meters (115,200bps-9,600bps).

III. Connector and signal

RS-232C bay-line distribution

RJ-45 PIN

DB 9 Female (PIN)	RS-232C Interface signal
1	Earth protection
2	Receive data SIN(RXD)
3	Send data SOUT(TXD)
4	Data terminal ready DTR
5	Ground signal GND
6	Data setting ready DSR
7	Request send RTS
8	Clear send CTS
9	Ring indication RI

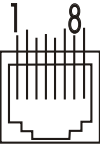

RS-485 output signal and connector end bay-line distribution

DB 9 Male (PIN)	RJ 45	Output signal	RS-485 half-duplex connection
1	1	T/R+	RS-485 (A+)
2	2	T/R-	RS-485 (B-)
3	3	N/C	None
4	6	N/C	None
5	4.5.7.8	GND	Underground line
6		VCC	Power supply: 9-24VDC input /
7		N/A	
8		N/A	
9		N/A	

IV. Hardware installment and application

Read the user manual carefully before installing the UT-2216 photoelectric isolation interface converter. Connect the attached communication cable to RS-232 interface, and insert the power supply converter to power socket. The product adopts the DB-9/DB-9 general used connector for input and output interface without jumper setting for RS-485 automatic communication mode. Either twisted pair cable or shielded cable is applicable for easy installation or un-installation. T/R+T/R- represents sending and receiving the A+/B-, VCC represents power input or output, GND represents public underground line. Point-to-point and point-to-multipoint

Half duplex communication use the two lines of T/R+ and T/R-, point-to-point and point-to-multipoint

UT-2216 interface converter supports the following 2 communication modes:

1. Point-to-point 2-line half duplex
2. Point-to-multipoint 2-line half duplex

In order to prevent the signal reflection or interference when converter is used in half-duplex mode, a proper matching resistance should be connected at the terminal of the line (120Ω 1/4W).

V. Communication connection chart

Conversion from RS-232 to RS-485

1. RS-485 point-to-point/2-line half duplex

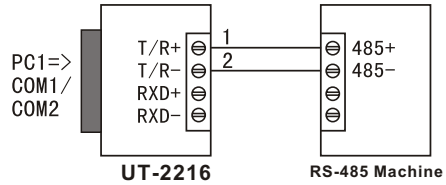

2. RS-485 point-to-multipoint/2-line half duplex

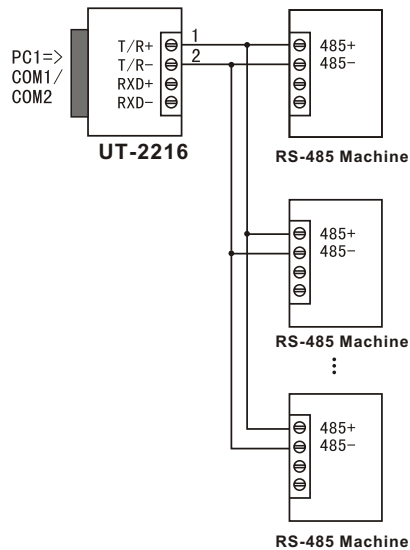

3. Half-duplex communication connections between UT-2216 interfaces

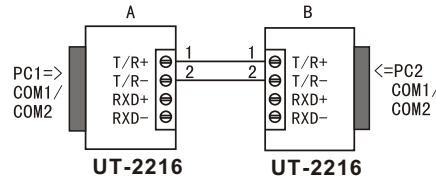

VI. Problems and resolutions

1. Data communication failure

- A. Make sure RS-232 interface connection is correct.
- B. Make sure RS-485 output interface connection is correct.
- C. Make sure power supply is OK.
- D. Make sure the wire terminal connection is OK.
- E. Make sure the pilot lamp flashes when receiving.
- F. Make sure the pilot lamp flashes when sending.

2. Data missing or incorrect

- A. Check to see whether if the data rate and format at both ends of the communication equipment are consistent.