

RS-232/RS-485 UT-2017 Passive Optical Isolation Interface Converter Instructions

I. Overview

UT-2017 passive optical isolation interface converter, compatible with RS-232C, RS-485 standard. To convert the RS-232 signals of single end to balance and difference signal of RS-485, Photoelectric isolator built-in, It can provide high isolation voltage up to 2500Vrms, With the fast transient voltage suppression protector, The protector is designed to protect the RS-485 interface, Using today's advanced TVS (TRANSIENT VOLTAGE SUPPRESSOR) transient voltage suppressor, Under normal circumstances, TVS pipe is in a high impedance state, When the TVS tube are subjected to moment when high energy impact, It can reduce the impedance of the two ends at high speed and absorb a large current. So it can make the two ends of the voltage clamp in a predetermined value. It protects the back circuit from being damaged by transient pressure impact. The protector can effectively suppress the lightning (LIGHTNING) and ESD, Provide lightning surge protection power per line 600W, And for various reasons produced on the line surge voltage and transient overvoltage, And the minimum capacitance ensures high-speed transmission of the RS-485 interface. The RS-232 interface is a DB9 female connector and is compatible with the RS-232C standard interface is connected by, The RS-485 end of the DB9 male head is used to output end. Inside the converter with zero delay automatic duplexer, the function of automatic control the data flow direction of I/O circuit is unique, Without any handshake signals (such as RTS, DTR etc.), Half duplex (RS-485) mode conversion, plug and play. Ensure that for all existing communication software and hardware interface, it is not need to revise the software which bases on RS-232 mode.

UT-2017 passive optical isolation interface converter can be point-to-point, Point to multipoint provides reliable connection, each converter allows to connect 32 RS-485 interface equipment in point to multipoint mode, 300-38400bps data communication rate, Support the communication mode from RS-232 to RS-485 conversion.

II. Performance parameter

- Interface characteristics: Interface compatible RS-232C and RS-485 standard of EIA/TIA
- Electrical interface: RS-232 interface input for the DB9 female connector, RS-485 interface output for DB9 male connector.
- Protection level: +/-15KV RS-232 interface ESD protection, Lightning surge protection for every line of the 600W RS-485 interface.

- Isolation: Isolation voltage 2500Vrms 500DC continuous
- Operation mode: Asynchronous half duplex
- Transmission medium : Twisted pair or shielded wire
- Transmission speed : 38400bps to 300M 9600bps to 1.2KM
- Outline: 63mm×33mm×17mm
- Using environment: -25 °C to 70 °C, relative humidity of 5% to 95%

III. Connector and signal

RS-232C pin configuration

DB9 female head/ pass (PIN)	RS-232C Interface signal
1	protected territory
2	Send information SOUT(TXD)
3	Receive data SIN(RXD)
4	Data terminal ready DTR
5	Signal ground GND
6	Data set ready DSR
7	Request to send RTS
8	Clear-to-send;CTS
9	Alarm instructions RI

RS-485 output signal pin assignments

DB9 male head	output signal	RS-485 Half duplex connection
1	T/R+	RS-485(A+)
2	T/R-	RS-485(B-)
3	N/C	Empty
4	N/C	Empty
5	GND	Earth wire
6.7.8.9	N/C	Empty

IV. Hardware installation and Application

Please read the instructions carefully before you install UT-2017 passive optical isolation interface converter, access the product to RS-232 port, This product adopts DB9 universal connector as input, DB9 male head as output, it can automatically set to RS-485 head communication mode Without jumper settings, Using twisted pair or shielded wire, it is easy to connect and dismantle, T/R+ and T/R- mean to transmitting and receiving A+ / B-, VCC is the the power of input or output, GND is the common ground, point to point, Point to multipoint, Half duplex communication with two lines T/R+, T/R-, point to point, Point to multipoint.

UT-2017 passive interface converter supports the following two kinds communication:

- Point to point / half duplex of two lines
- Point to multipoint / half duplex of two lines

V. Schematic diagram of the communication connection

RS-232 to RS-485 conversion

- RS-485 Point to point /half duplex of two lines

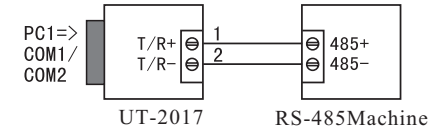

- RS-485 Point to multipoint /half duplex of two lines

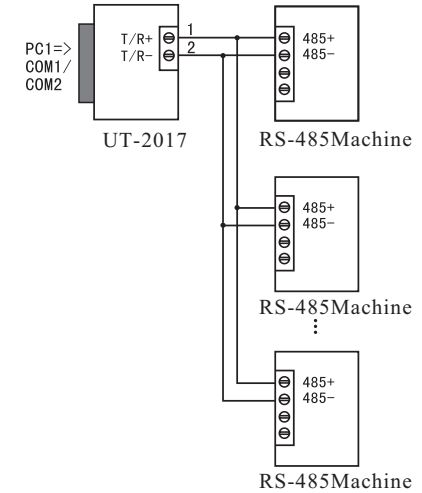

- UT-2017 Half duplex communication connection between interface converter

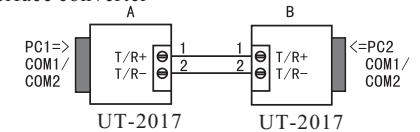

VI. Fault and troubleshooting

- Data communication failure
 - Please check the RS-232 interface wiring is correct or not
 - Check the RS-485 output interface wiring is correct
 - Check whether the power supply is normal or not
 - Check wiring terminal is connected well
 - Check the indicating lamp of receiving is flashing or not, When device is receiving the data
 - Check the indicating lamp of sending is flashing or not, when the device is sending the data
- Missing or wrong data

Check the data rate of the communication devices at the two ends and format are consistent or not.